

Product info sheet no. C 4.7

Humidity/-temperature sensors

for industrial applications up to 200°C, up to 25 bar

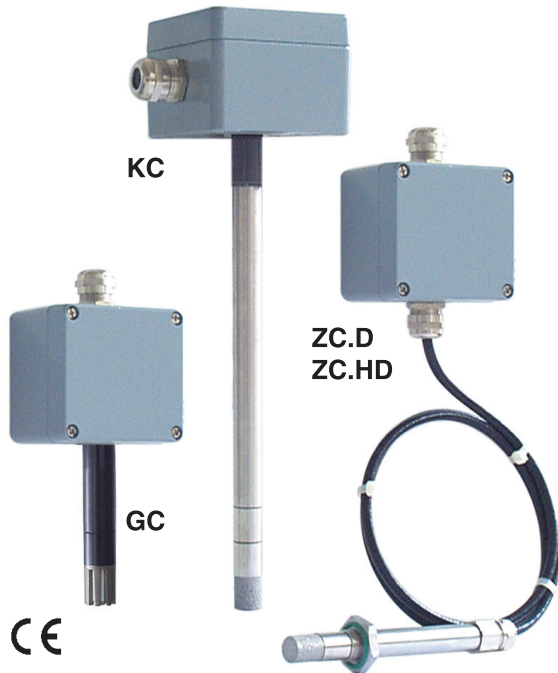

Description

MELA®-humidity/-temperature sensors in this series are supplied with a robust aluminium die cast housing with an inox or aluminium sensor part to measure relative humidity or relative humidity and temperature in air and other non-aggressive gases for a working temperature range of up to 200°C.

The pressure-proof executions „D“ and „HD“ can be used at pressures up to 25 bar, at temperatures up to 125°C or up to 160°C. These sensors are ideally suited for industrial applications, e.g. in drying processes.

The advantages of the series .../9 are its improved dynamics, in particular at low air speeds and also its increased service life, even under more challenging operating conditions (pollutant impact or permanent humidity > 95 %rh). When air speeds are extremely high combined with a high number of particles, using the series .../9 is not recommended.

Technical data

Humidity

measuring range 0...100%rh
 accuracy (10...40°C; 5...95%rh) ±2.0%rh
 influence of temperature <10°C, >40°C <0.1%/K

Temperature

measuring element (ref. DIN EN 60751) Pt 100 class B
 measuring range
 series GC..... -20...+80°C
 series ZC, ZC.D, KC -25...+125°C
 series ZCx.H, ZCx.HD 0...+200°C
 accuracy output: 0...10 V ±0.2 K
 output: 4...20 mA ±0.3 K
 influence of temperature <10°C, >40°C..... ±0.007 K/K

Other data

ambient temperature
 transmitter part -40...+80°C
 sensor part series GC -40...+80°C
 series ZC, KC, ZC.D -40...+125°C
 series ZC.HD -40... +160°C
 series ZC.H -60... +200°C
 operating voltage
 current output 2-wire...12...30V DC
 voltage output 3/4-wire... 24V±10% AC
 or 15...30 V DC

degree of protection
 transmitter part IP 65
 sensor part (xKC, xZC) IP65
 Sensor part (xGC) IP30

housing material
 sensor part (except series GC) inox
 sensor part series GC aluminium
 transmitter part pressure die casting of alu

load:
 (current output) $\Omega = \frac{\text{operating voltage} - 10 \text{ V DC}}{0.02 \text{ A}} \pm 50\Omega$

load resistance (voltage output) ≥10kΩ
 power consumption (voltage output) <5mA
 electromagnetic compatibility

emitted interference EN 55011 cl.B
 noise immunity EN 50082-2

„subject to technical modifications“

Special versions available on request

Type Versions (Order designation)

Measured variable	Analogue output	GC series wall mounted	KC series duct mounted	ZC series two-piece
F rel. humidity	0...20 mA	FGC 4/x	FKC 4/x	FZC 4/x
	4...20 mA	FGC 3/x	FKC 3/x	FZC 3/x
	0...10 V	FGC 2/x	FKC 2/x	FZC 2/x
C r.h. + temp.	0...20 mA, Pt100	CGC 4/x	CKC 4/x	CZC 4/x
	4...20 mA, Pt100	CGC 3/x	CKC 3/x	CZC 3/x
	0...10 V, Pt100	CGC 2/x	CKC 2/x	CZC 2/x
K r.h. + temp.	2 x 4...20 mA	KGC 3/x	KKC 3/x	KZC 3/x
	2 x 0...10 V	KGC 2/x	KKC 2/x	KZC 2/x
T temperature	Pt 100	TGC 5/5	TKC 5/5	
	4...20 mA	TGC 3/5	TKC 3/5	
	0...10 V	TGC 2/5	TKC 2/5	
weight approx.		380 g	470 g	500 g

/x please select the appropriate filter (refer also to datasheet F5.1)

series GC: open protective basket ZE16 → **x=5**
 integr. element filter made of PTFE and ZE16 → **x=9**
 series KC,ZC: sintered inox filter ZE13 → **x=5**
 integr. element filter made PTFE and ZE14 → **x=9**

Measured variable	Analogue output	ZC.D series 25 bar	ZC.H series 200°C	ZC.HD series 25bar, 160°C
F rel. humidity	0...20 mA	FZC 4.D/x	FZC 4.H/x	FZC 4.HD/x
	4...20 mA	FZC 3.D/x	FZC 3.H/x	FZC 3.HD/x
	0...10 V	FZC 2.D/x	FZC 2.H/x	FZC 2.HD/x
C r.h. + temp.	0...20 mA, Pt100	CZC 4.D/x	CZC 4.H/x	CZC 4.HD/x
	4...20 mA, Pt100	CZC 3.D/x	CZC 3.H/x	CZC 3.HD/x
	0...10 V, Pt100	CZC 2.D/x	CZC 2.H/x	CZC 2.HD/x
K r.h. + temp.	2 x 4...20 mA	KZC 3.D/x	KZC 3.H/x	KZC 3.HD/x
	2 x 0...10 V	KZC 2.D/x	KZC 2.H/x	KZC 2.HD/x
Weight approx.		520 g	520 g	520 g

/x please select the appropriate filter (refer also to datasheet F5.1)

series ZC.H, ZC.D, ZC.HD
 sintered inox filter ZE13 → **x=6**
 integr. element filter made PTFE and ZE1 → **x=9**

User instructions

Install the MELA®- humidity/temperature sensors in a place where characteristic climatic conditions can be measured. We recommend to use the MELA®-**ZA 24-type mounting plate** (product info sheet no. F 5.1) for wall or duct-mounting.

The sensor can be installed in any position. However, do not position it in a position where water ingress can occur. Dew formation and splashes do not damage the sensor, although corrupted measurement readings are recorded until all the moisture on and directly around the sensor element has dried up.

In order to maintain interference immunity in accordance with EN 80082-2 when it is in use, we recommend to use a screened cable (type recommended: **8x AWG26 C UL order no. 5339**) for connecting the sensors, and have this fitted into the sensor's EMC heavy-gauge conduit thread by a qualified electrician.

In order to check functioning in the place of installation, we recommend that you use the MELA®-**ZE31/1-type humidity standard** with a **ZE 33-type auxiliary adapter** (product info sheet no. F 5.2).

Dust does not cause any harm to the humidity sensor, however, it does affect dynamic performance.

If there is an excessive build-up of dust then you can carefully unscrew the stainless steel protective cap ZE 14 on the series .../9 and carefully rinse the sensor head with distilled water. The element filter made of PTFE is not exchangeable.

On the series .../5 and .../6 the stainless steel sinter filter ZE13 can also be unscrewed and rinsed out with distilled water. Loose dirt can also be removed from the measuring element by blowing it off or by rinsing it carefully with distilled water. In order to avoid corrupted measurement readings, only screw the sintered inox filter ZE13 back on when it is completely dry. Do not touch the highly sensitive sensor

element.

Please consult the **application instructions** for the sensing elements (product info sheet no. A 1) or check with the manufacturer for further information which you need to bear in mind when using humidity sensors with capacitive sensing elements.

Caution! When you install the pressure-proof sensors (series ZC.D and ZC.HD), do not apply a torque in excess of 25 Nm.

Sensors with voltage output have no galvanic separation between output and operating voltage at the negative pole.

The humidity output and temperature output of sensors with current output are always galvanically separated from each other!

Tolerance validity range for humidity

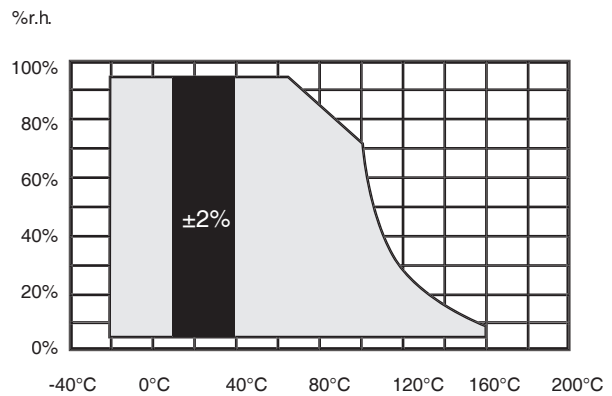

Dimensions

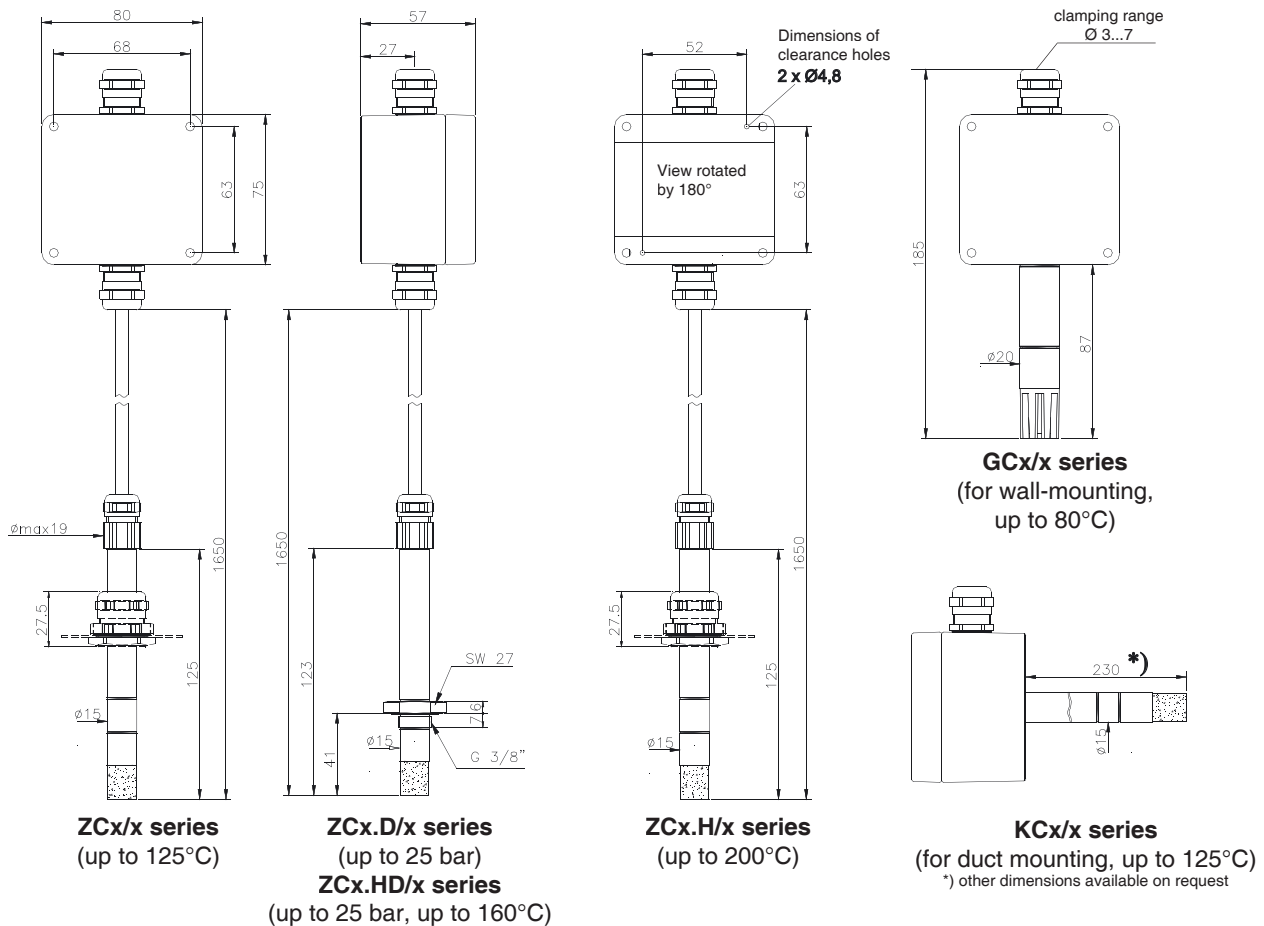

Connection diagram

Humidity/- temperature sensors

for industrial applications up to 200°C, up to 25 bar

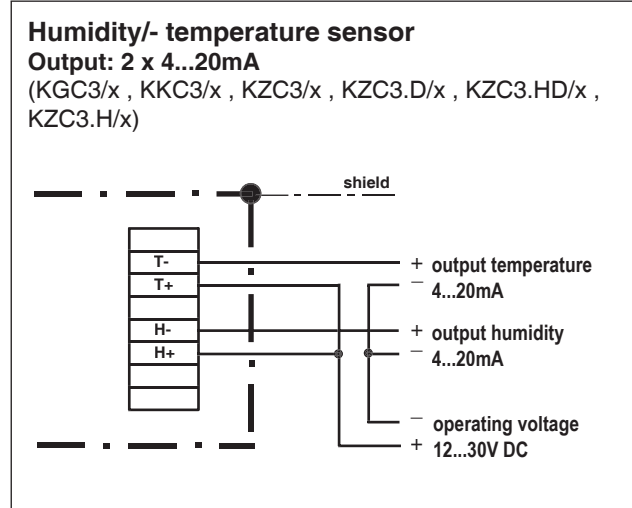
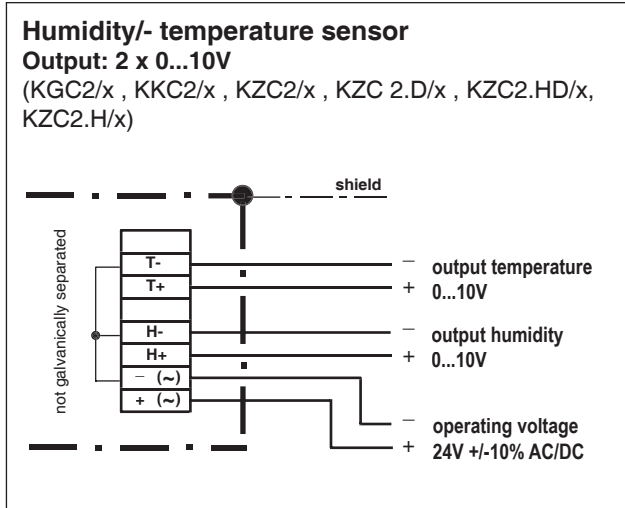

The electrical connection must only be carried out by properly qualified personnel.

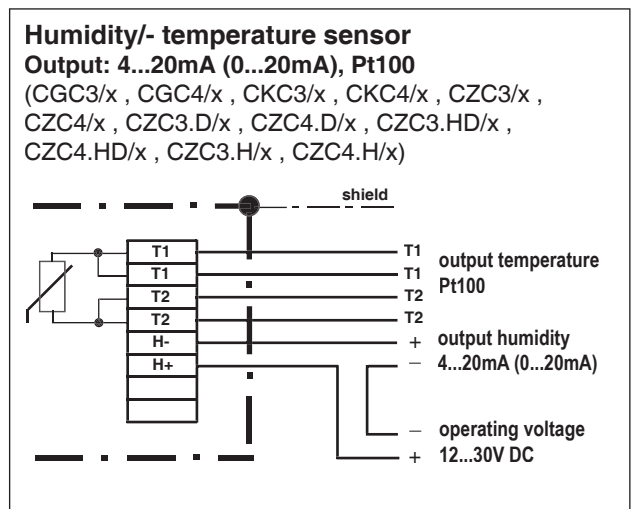
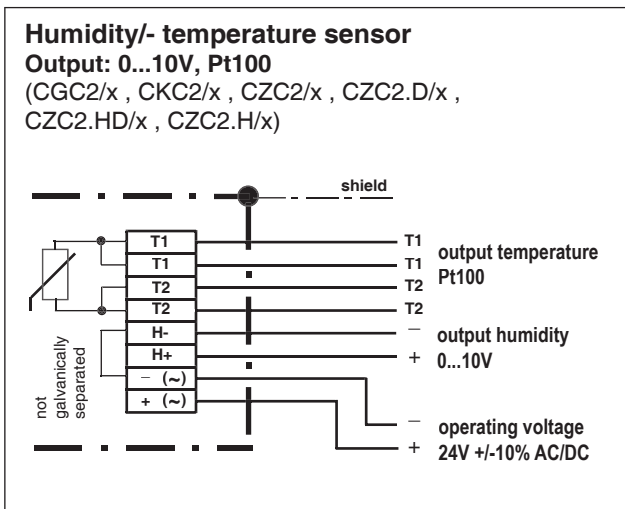
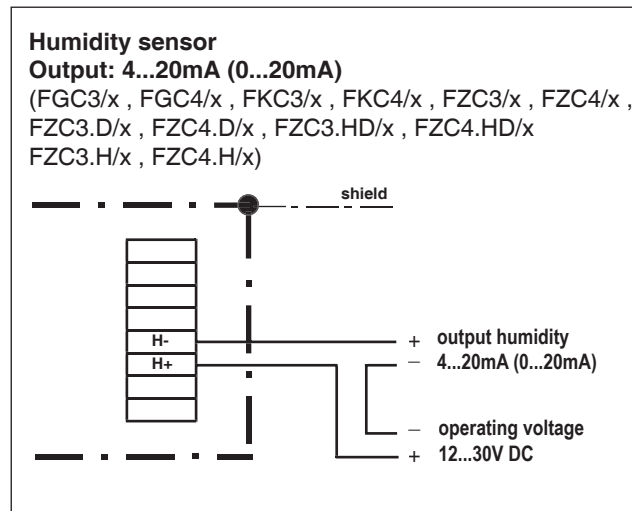
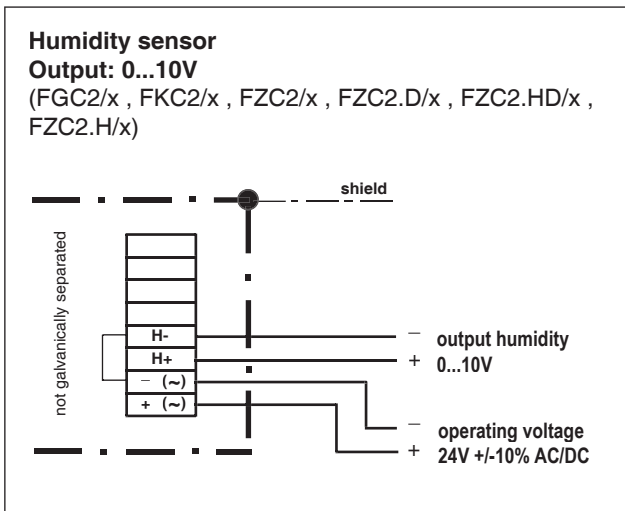

Connection diagram

Humidity/- temperature sensors

for industrial applications up to 200°C, up to 25 bar

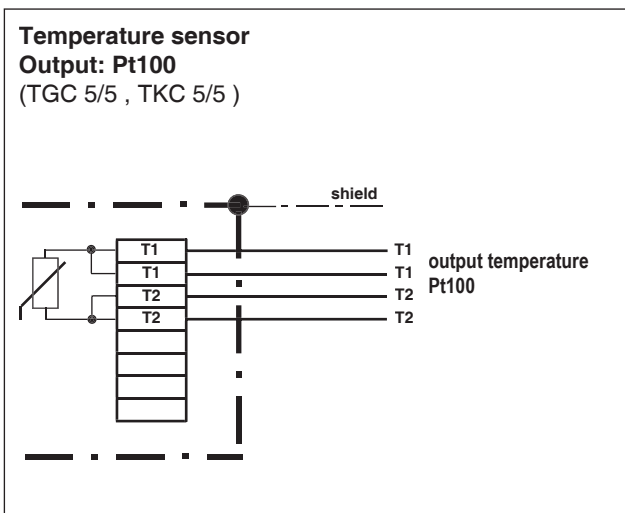
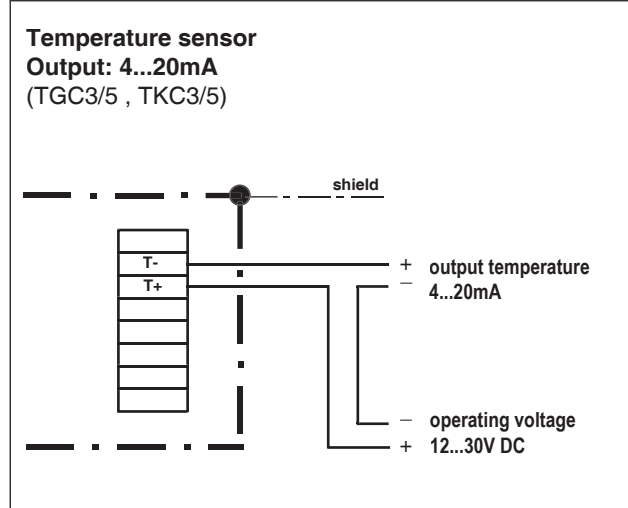
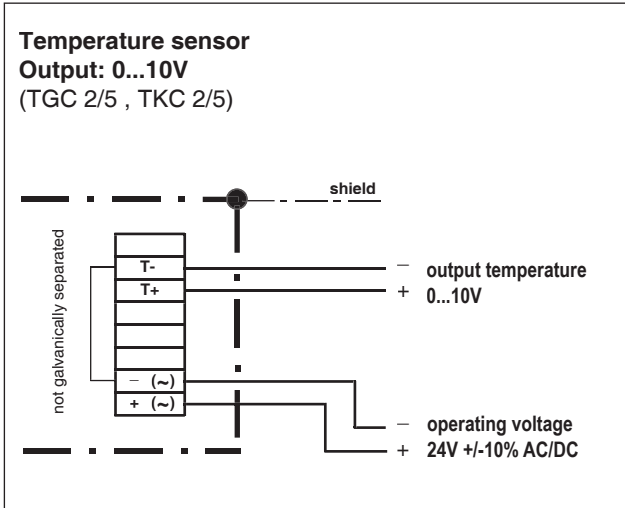

 The electrical connection must only be carried out by properly qualified personnel.